

# FMS MOLLES TORSIÓ

## Sistema Doble Guía

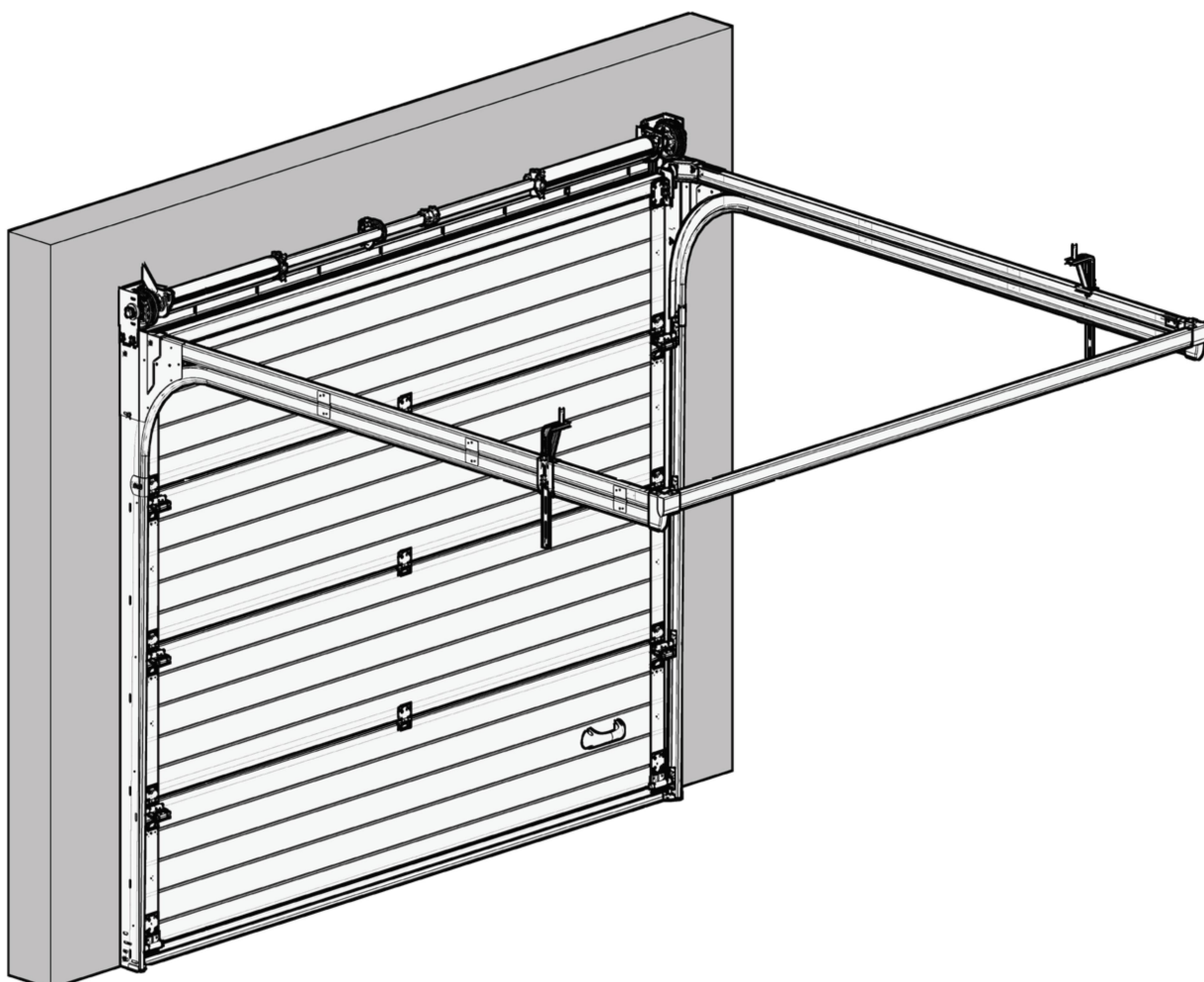

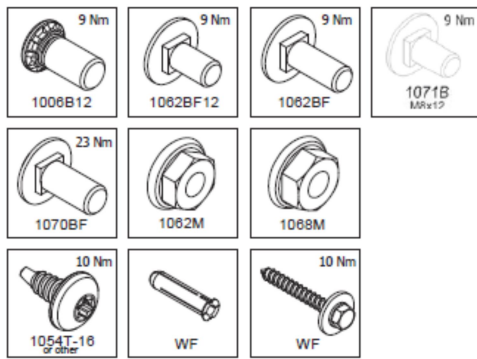

01 135 995 Rev. 14-08-2018

1

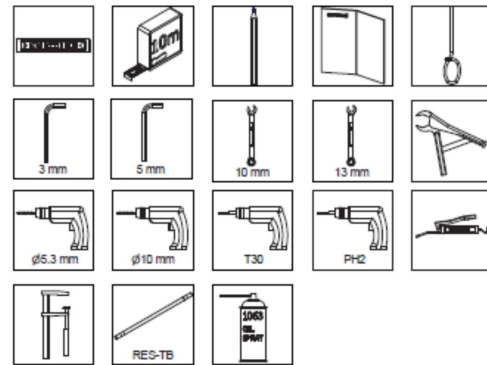

01 135 995 Rev. 14-08-2018

2

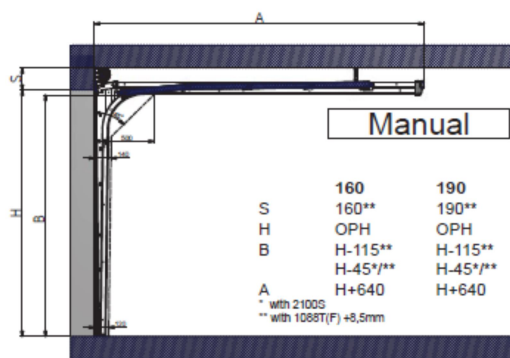

01 135 995 Rev. 14-08-2018

3

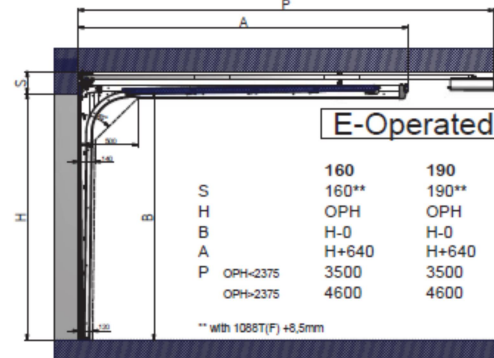

01 135 995 Rev. 14-08-2018

4

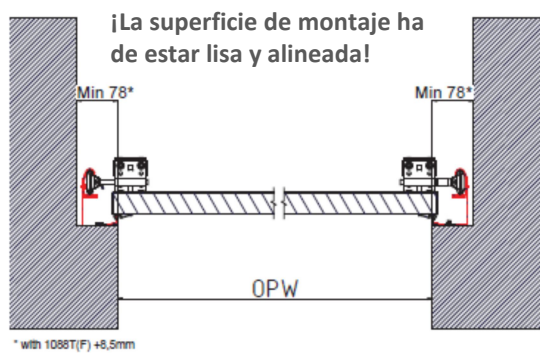

01 135 995 Rev. 14-08-2018

5

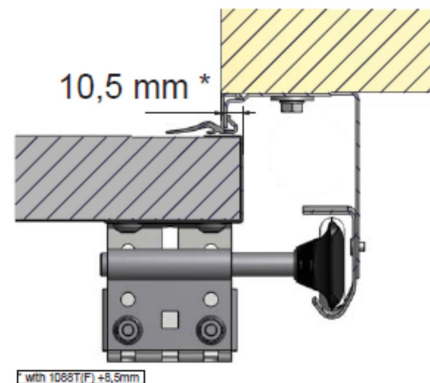

01 135 995 Rev. 14-08-2018

6

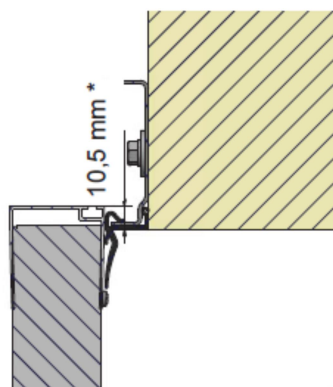

01 135 995 Rev. 14-08-2018

7

**Opciones de tipo guía vertical**



01 135 995 Rev. 14-08-2018

8

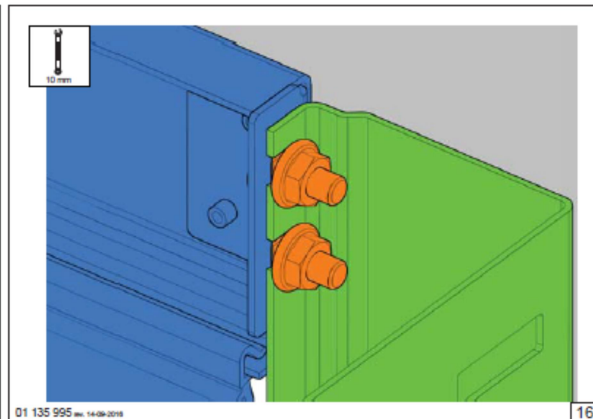
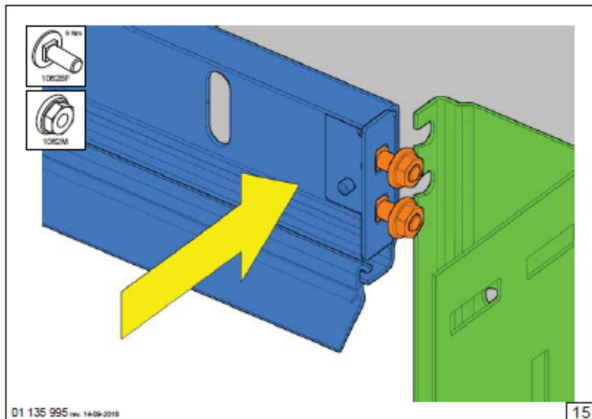
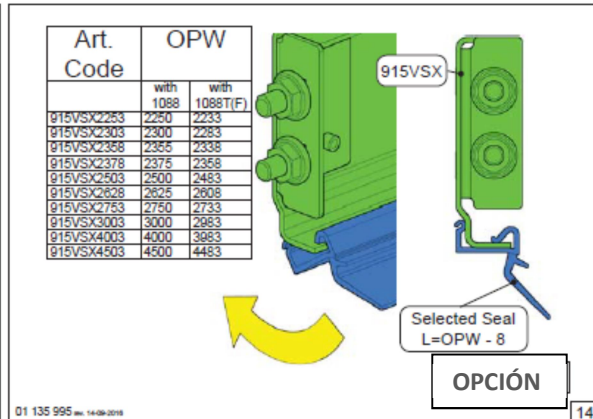
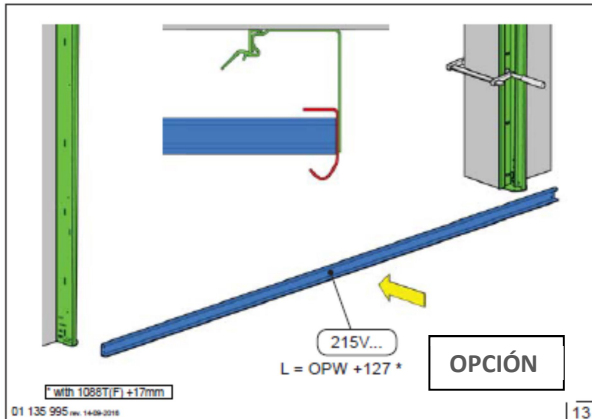
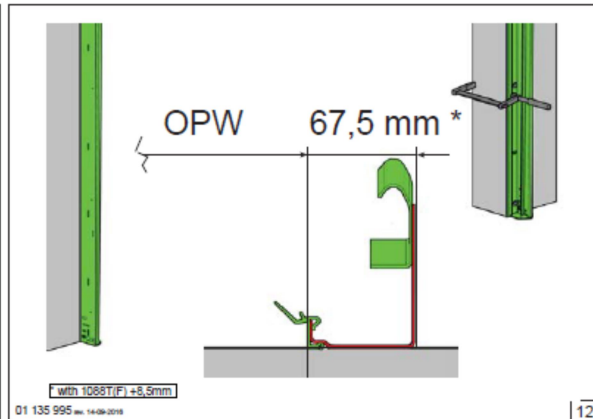
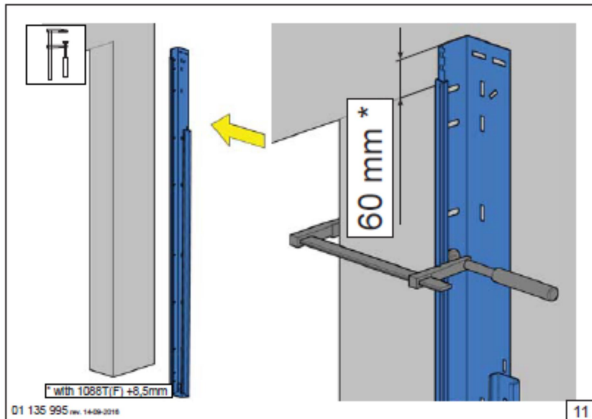
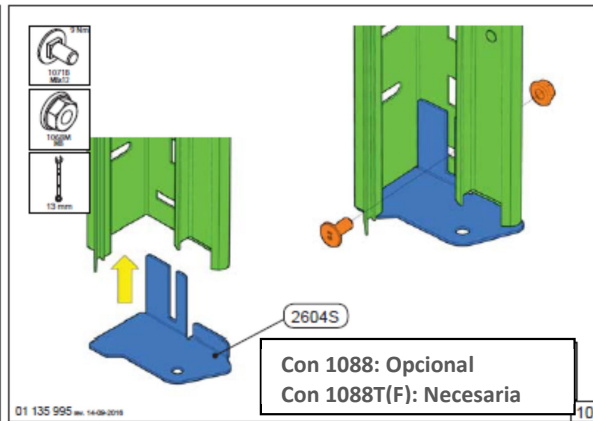
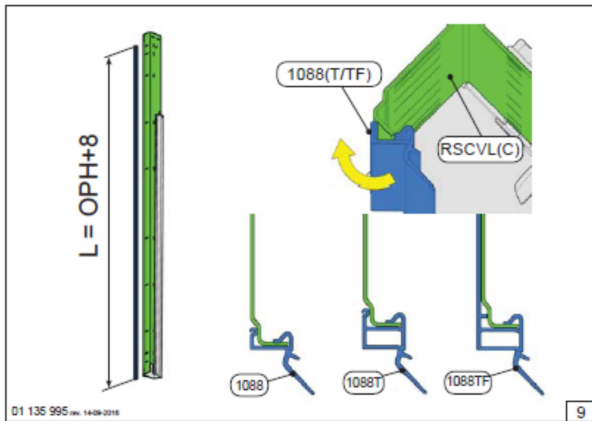

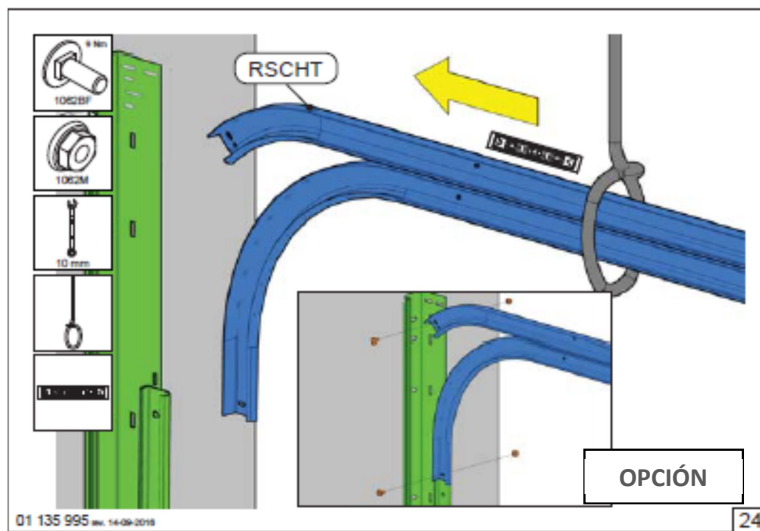
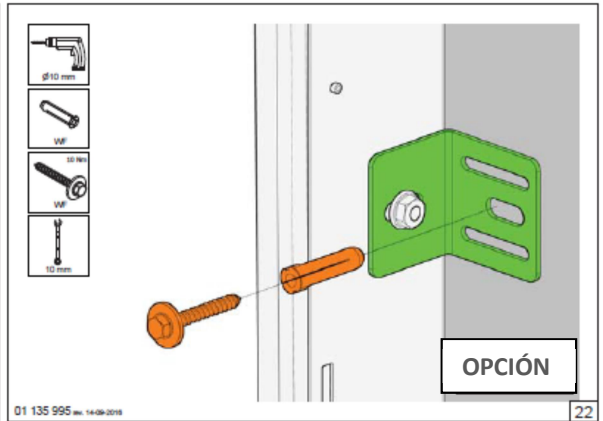
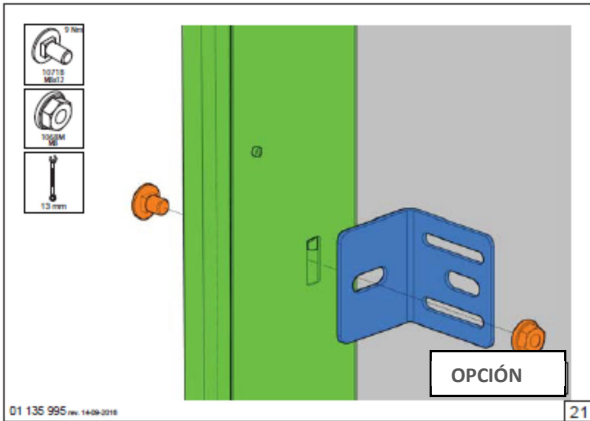
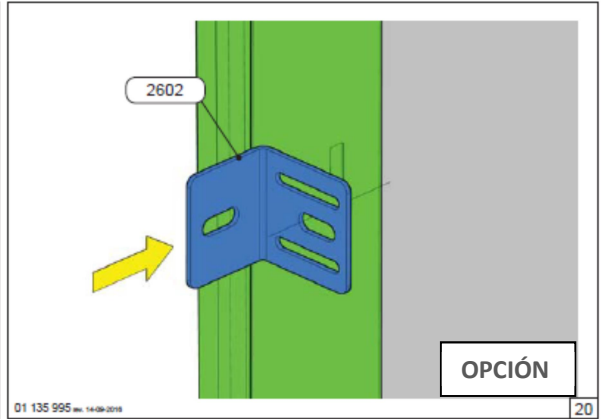
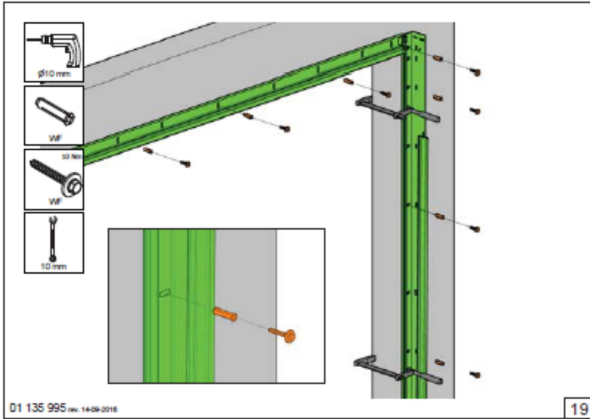
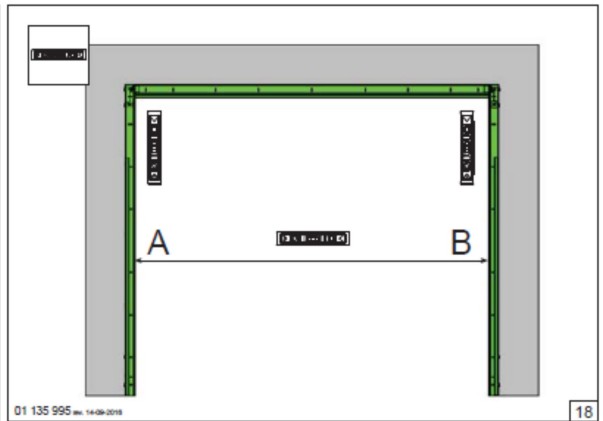
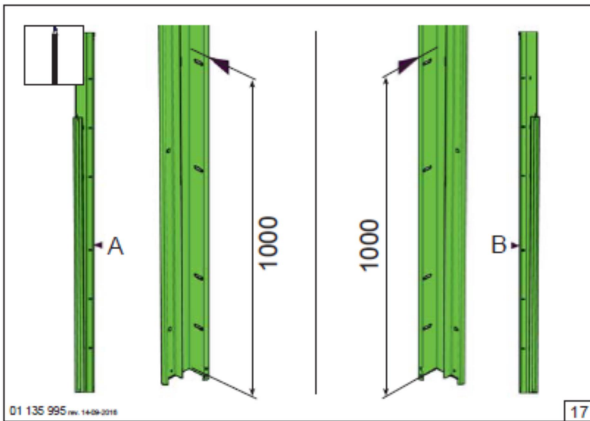

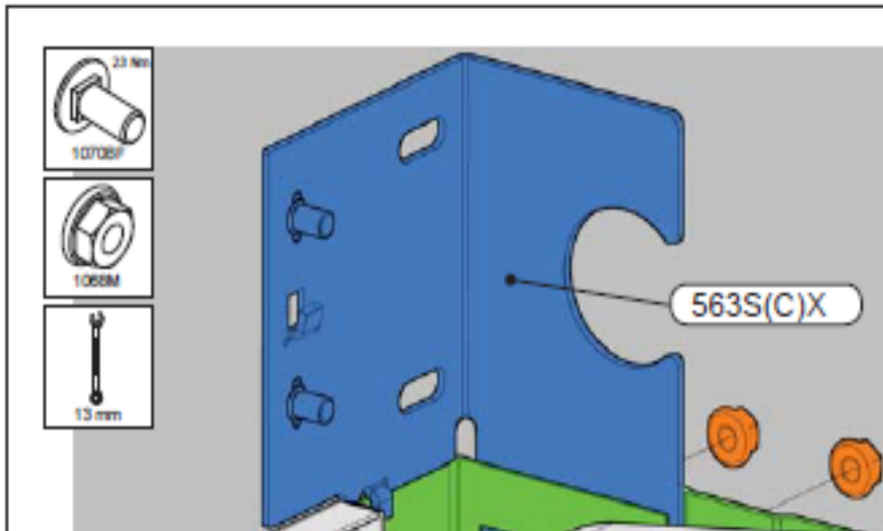
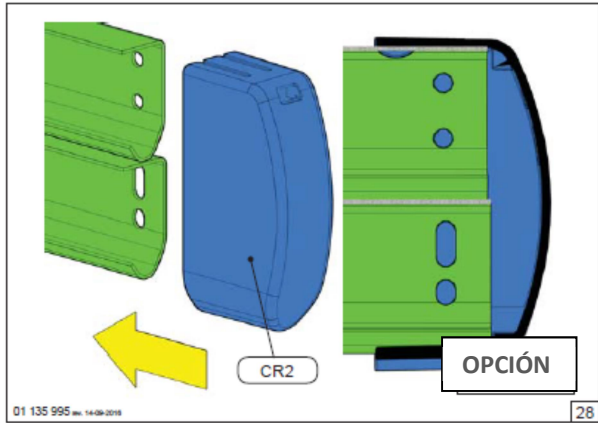
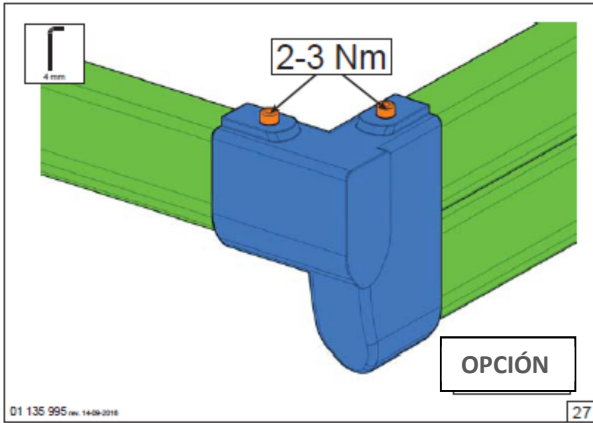
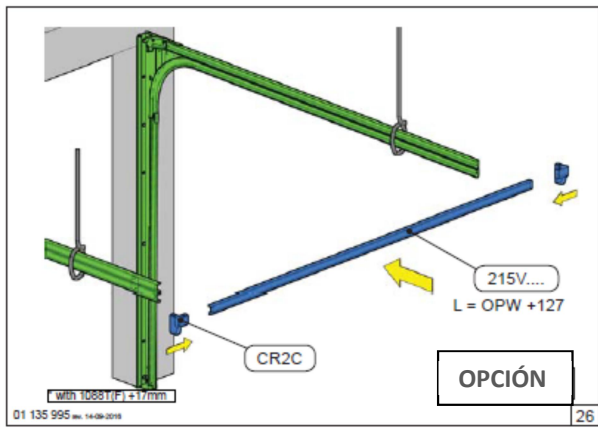
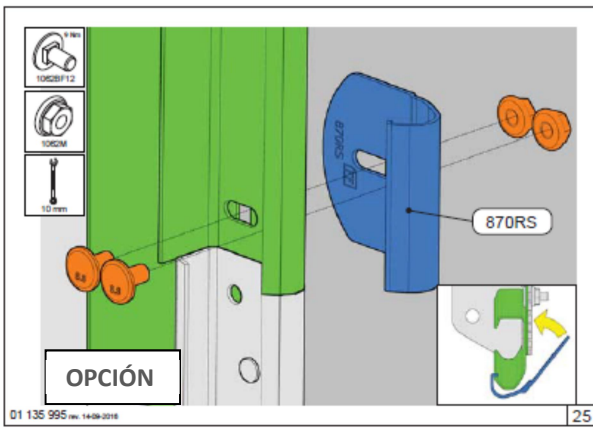

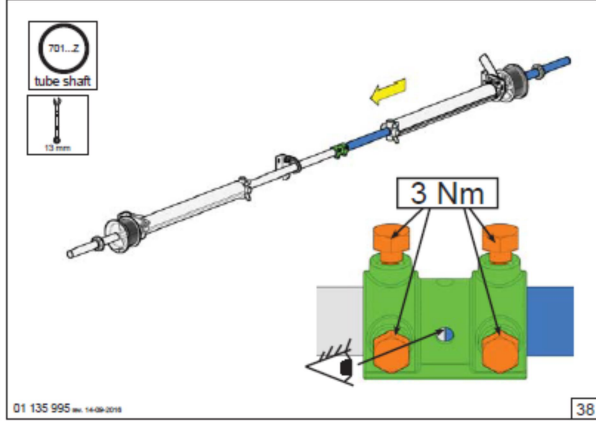
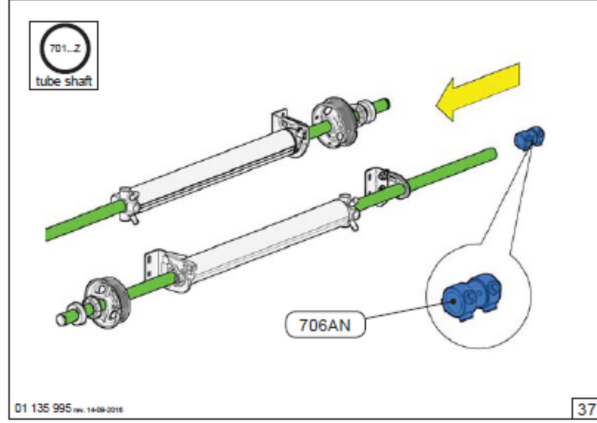
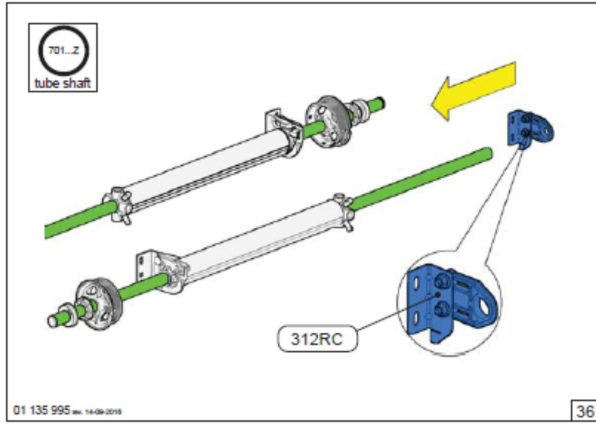
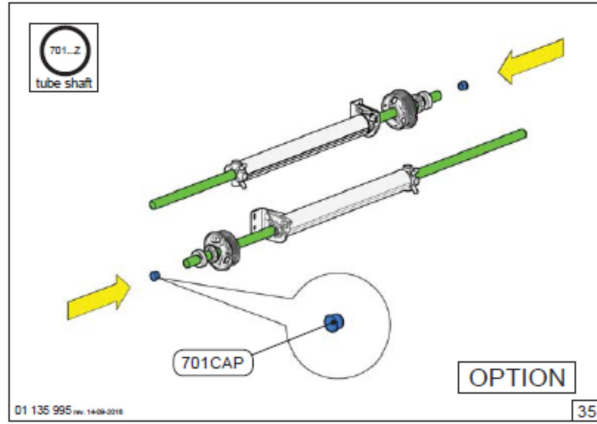
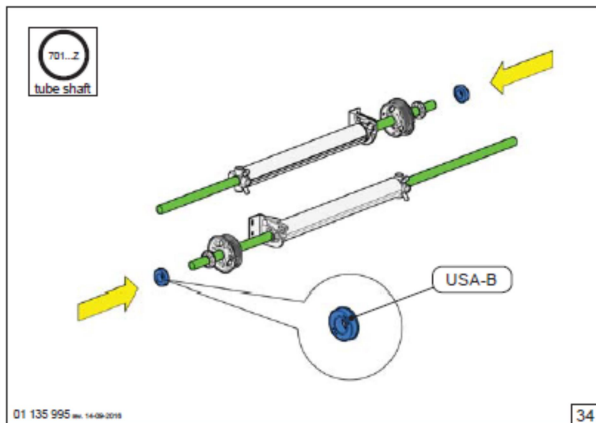
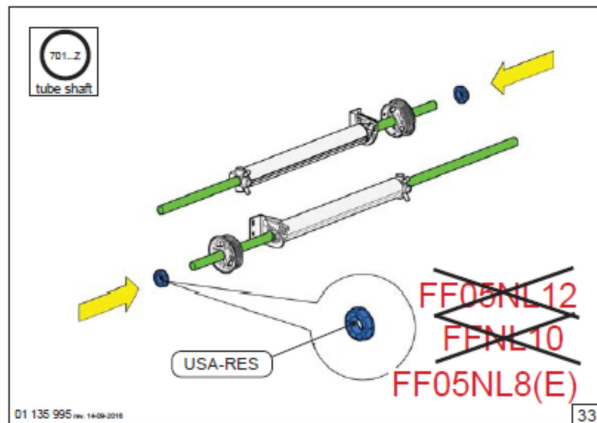
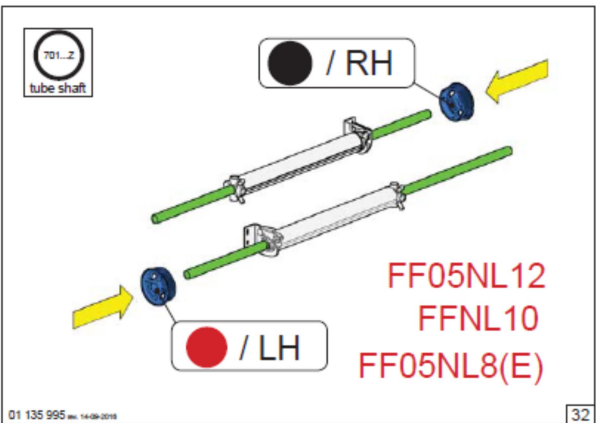
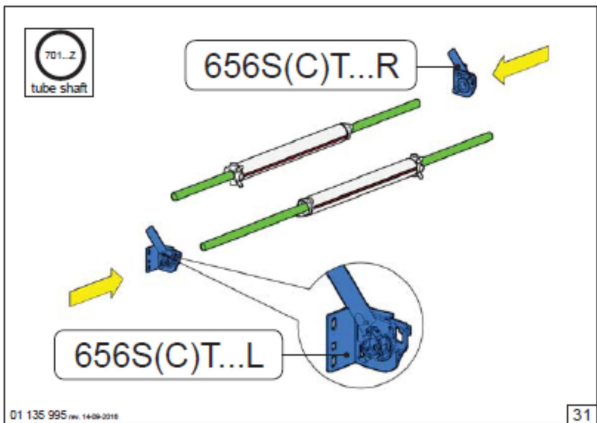

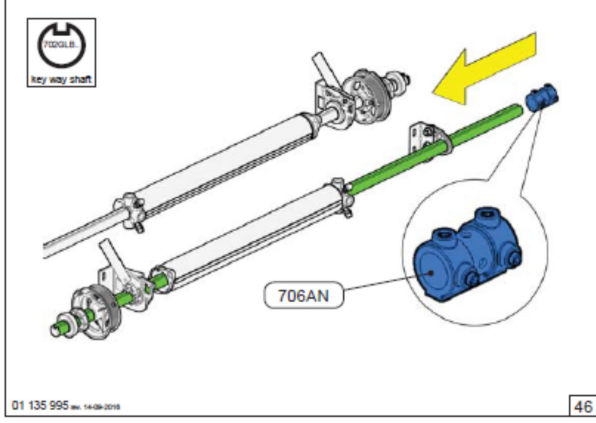
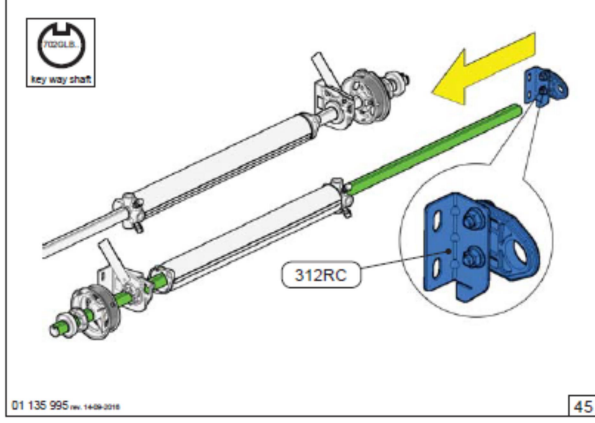
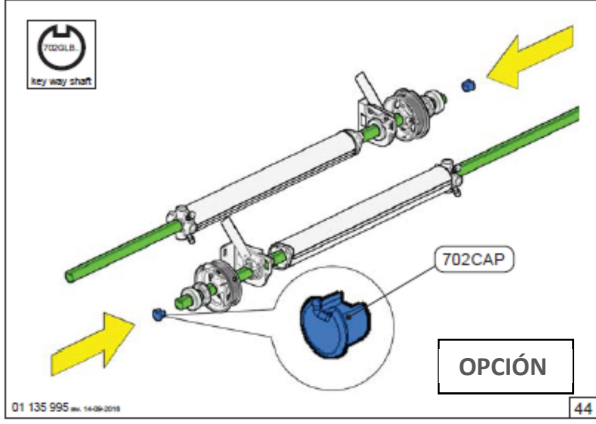
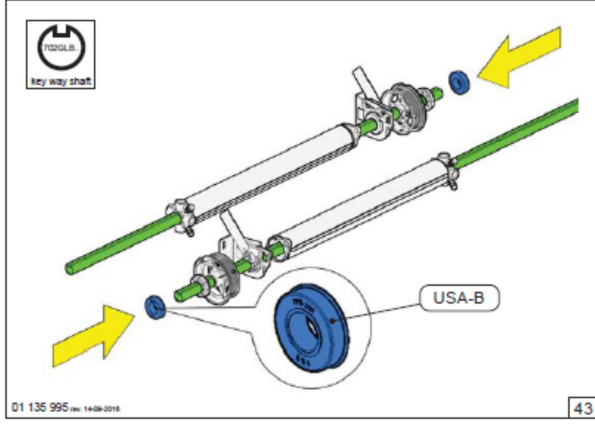
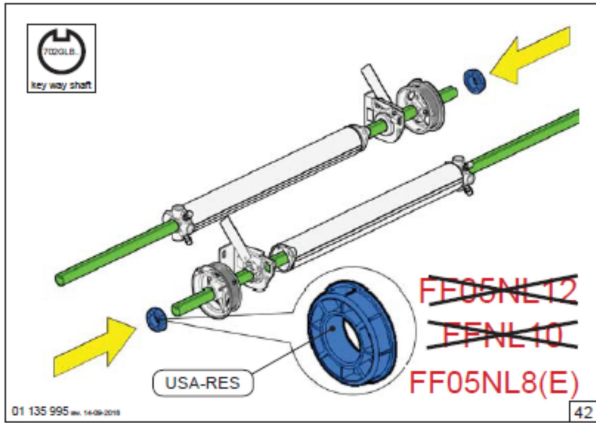
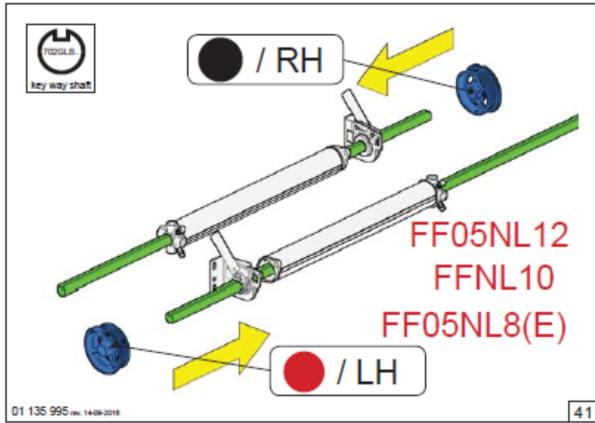
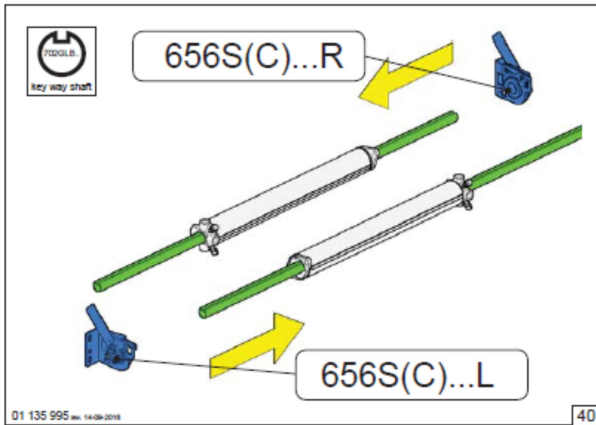
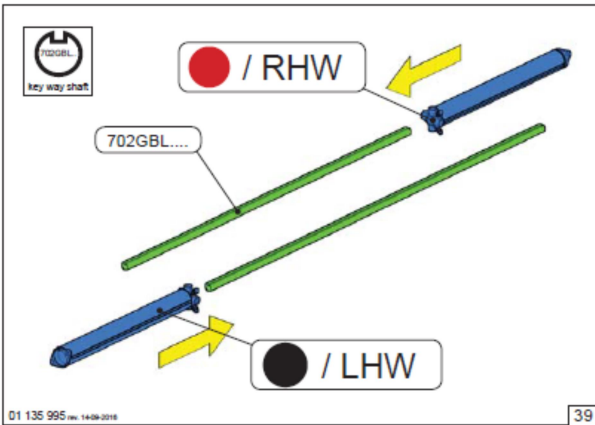

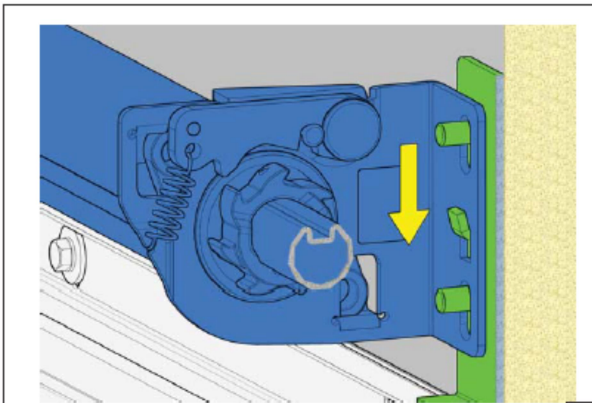

01 135 995 rev. 14-09-2016

49

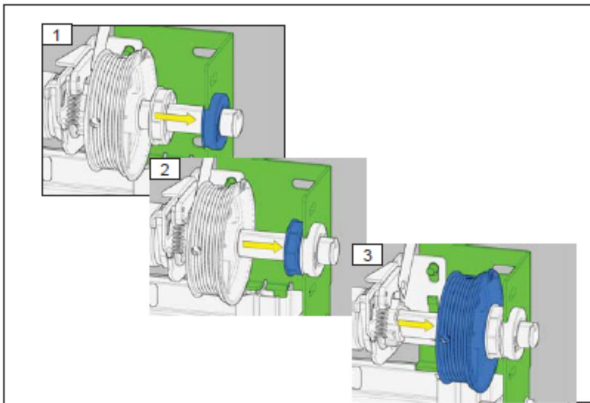

01 135 995 rev. 14-09-2016

50

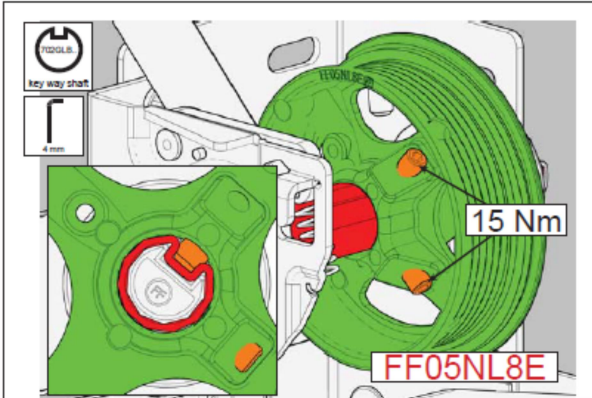

01 135 995 rev. 14-09-2016

51

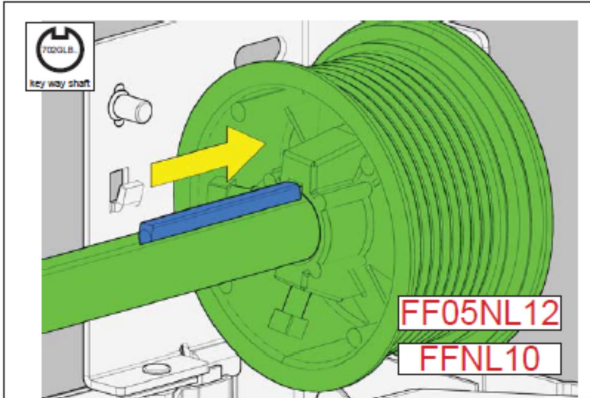

01 135 995 rev. 14-09-2016

52

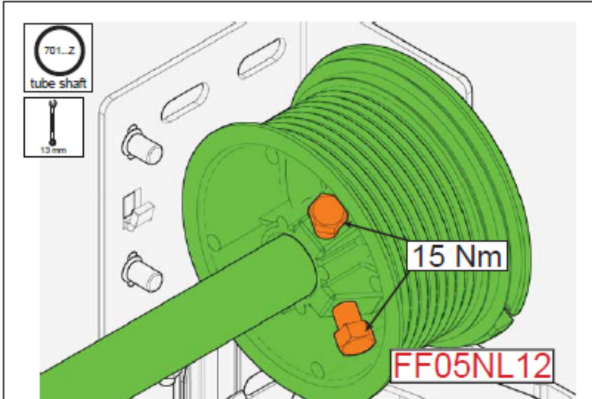

01 135 995 rev. 14-09-2016

53

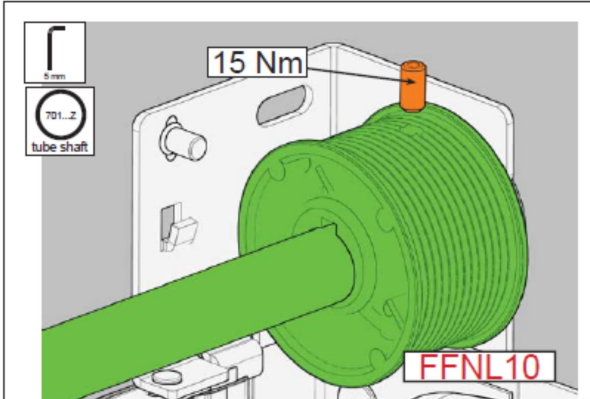

01 135 995 rev. 14-09-2016

54

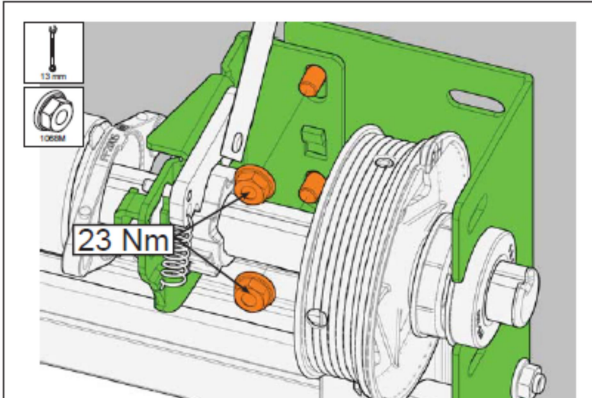

01 135 995 rev. 14-09-2016

55

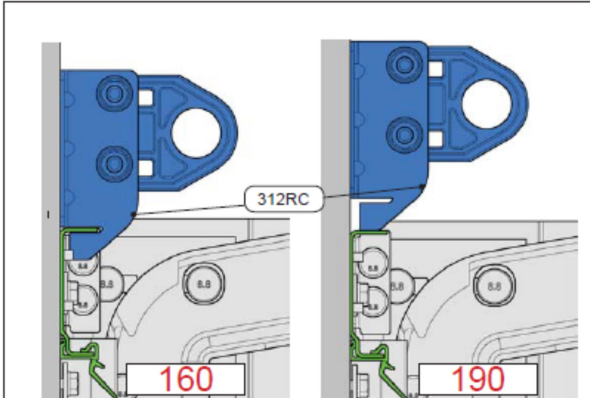

01 135 995 rev. 14-09-2016

56



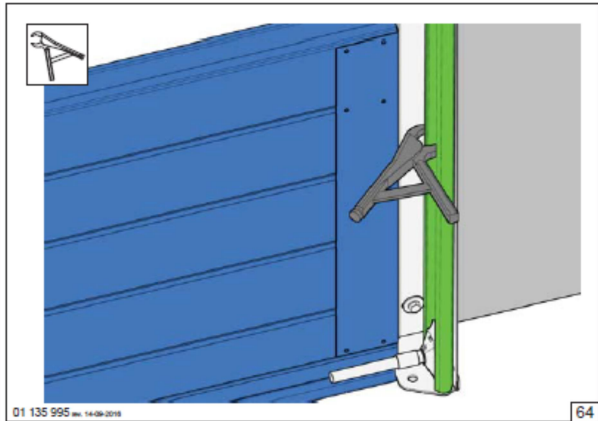
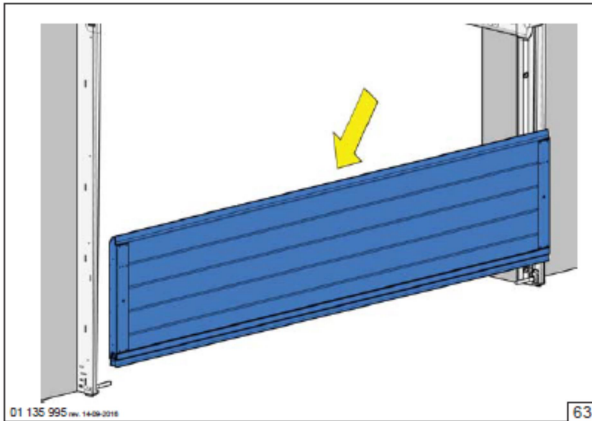
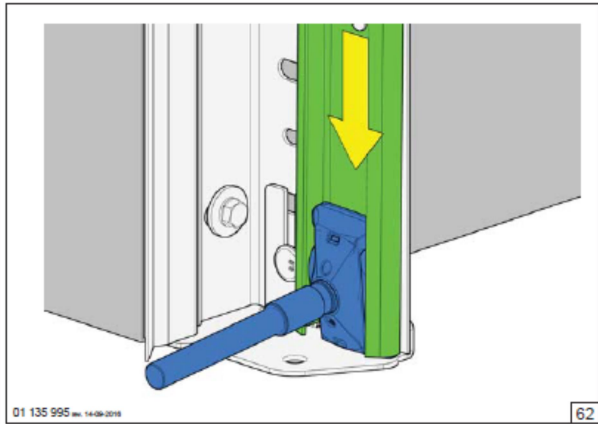
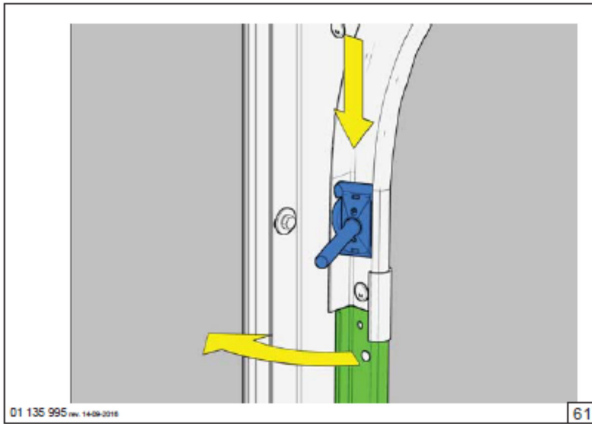
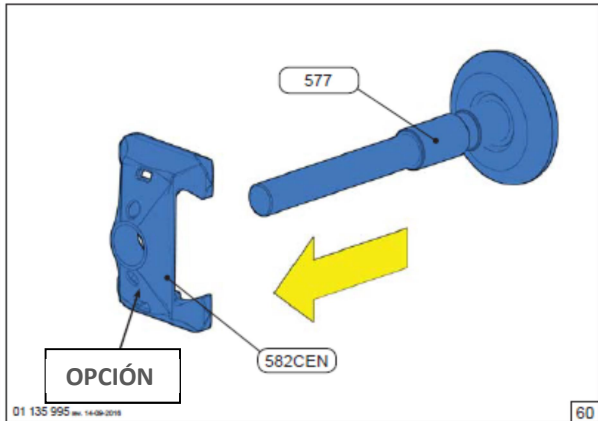
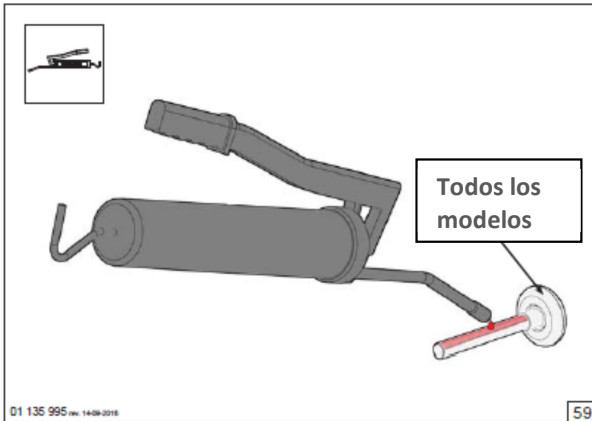
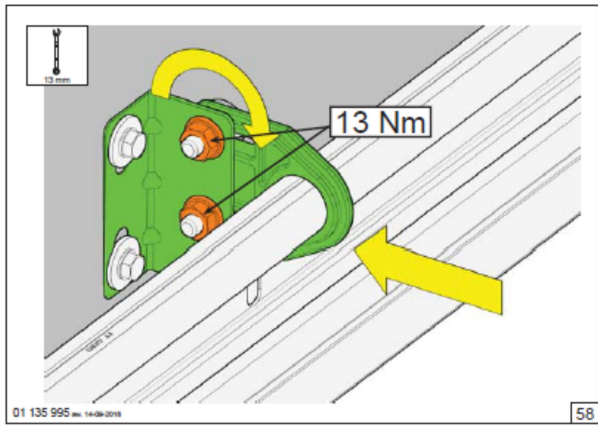
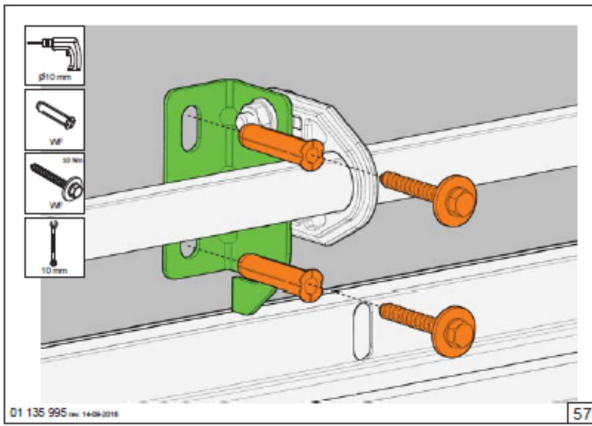

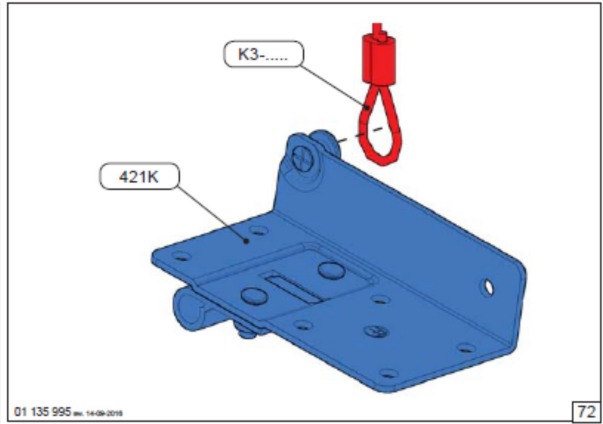
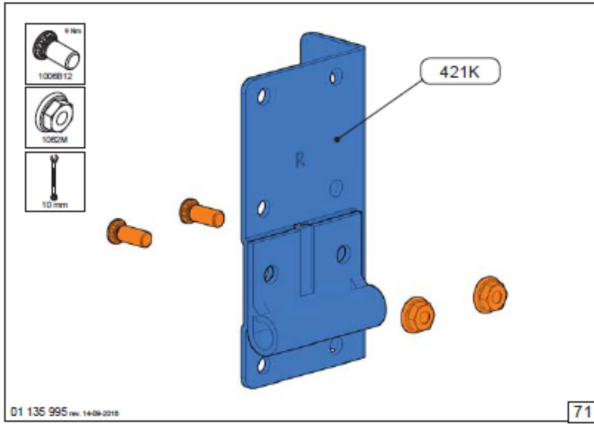
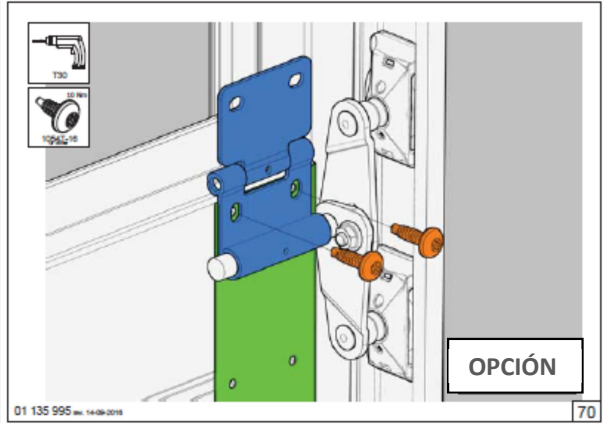
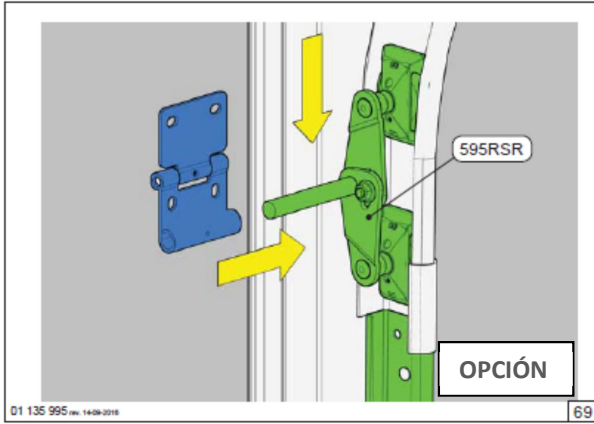
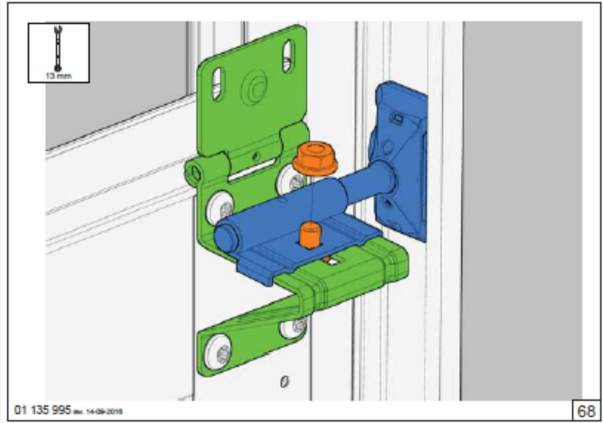
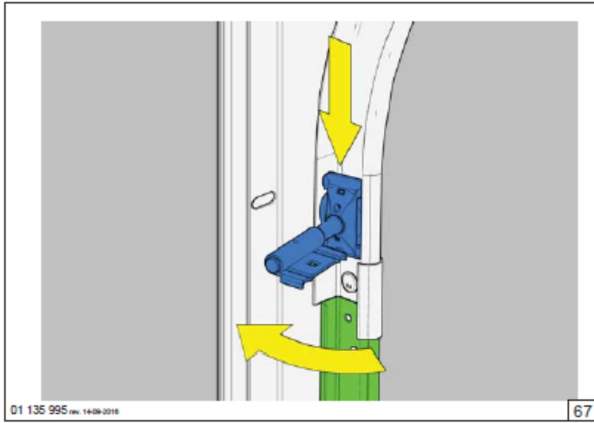
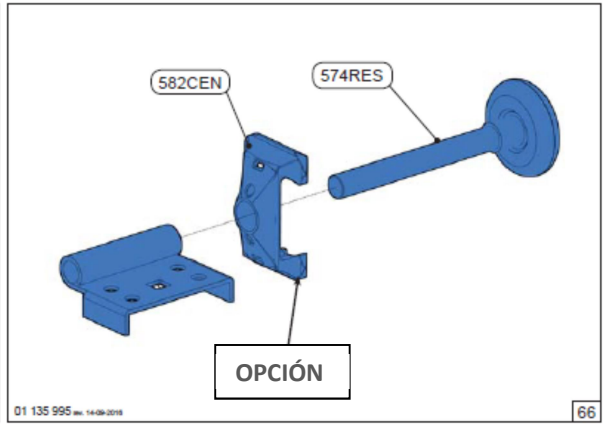
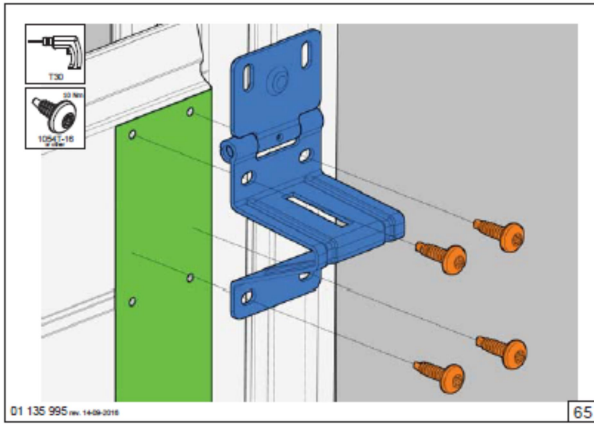

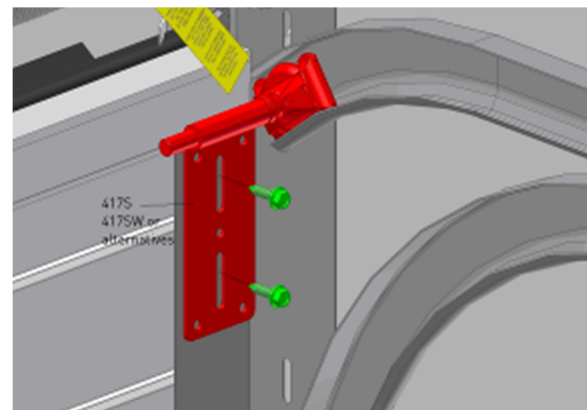
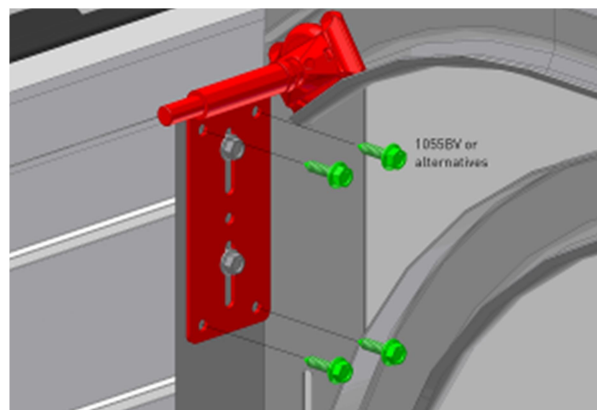
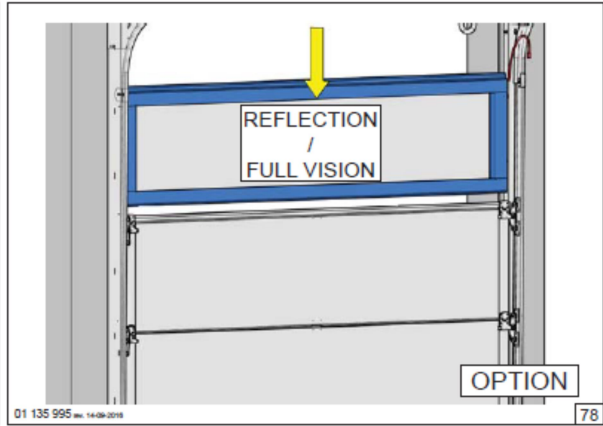
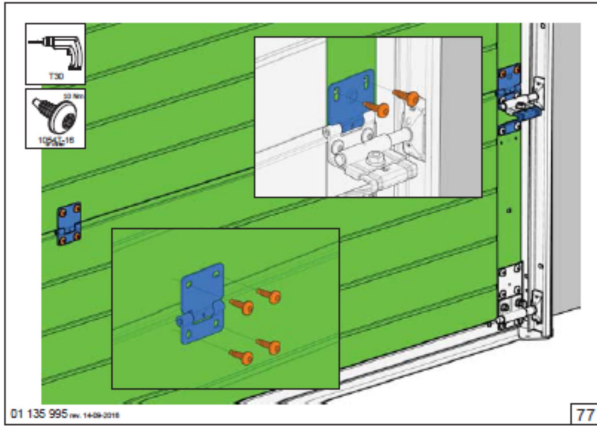
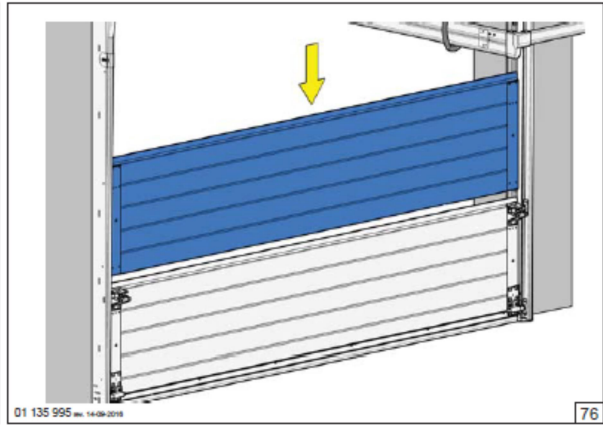
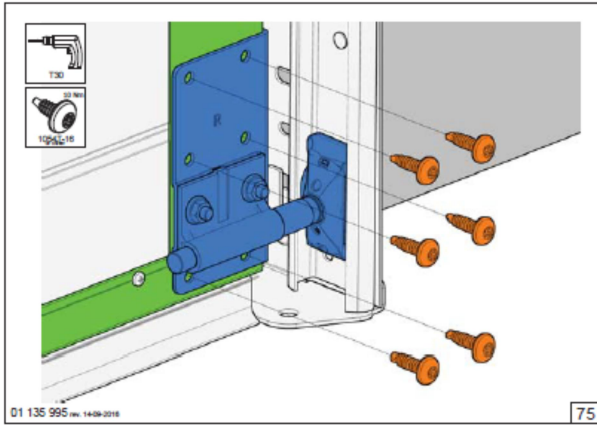
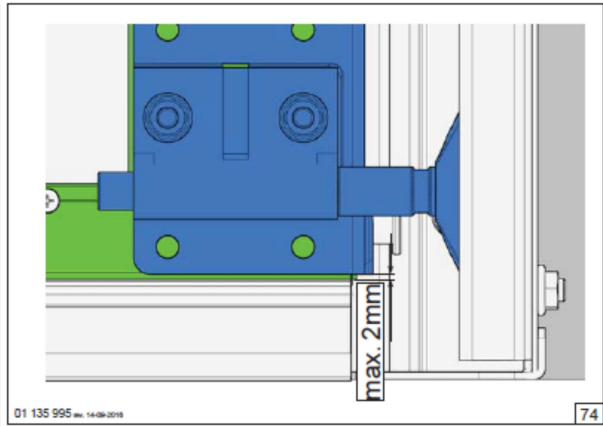
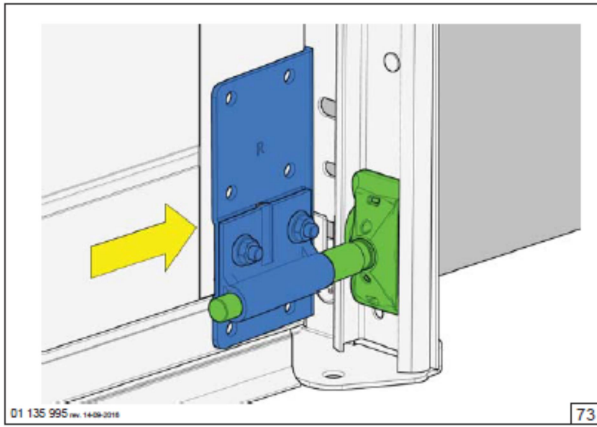

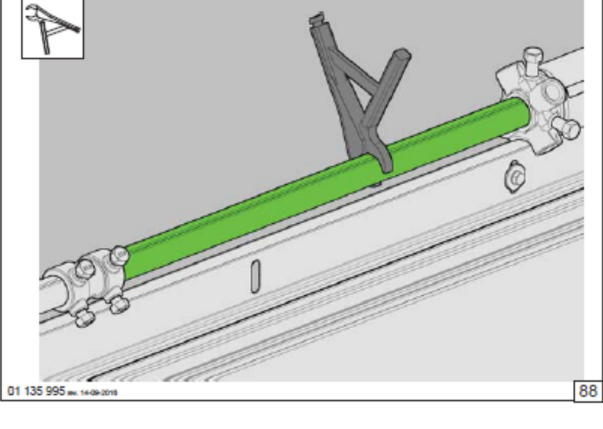
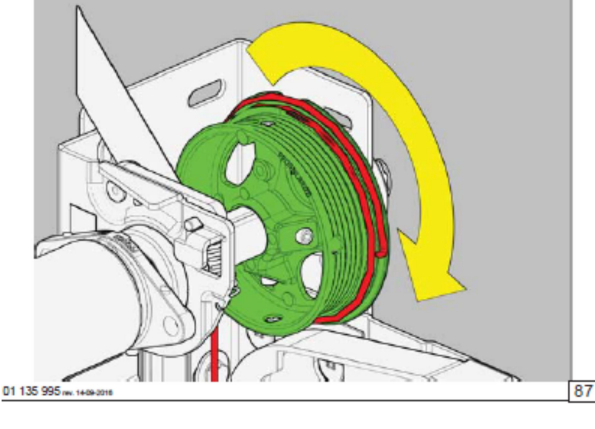
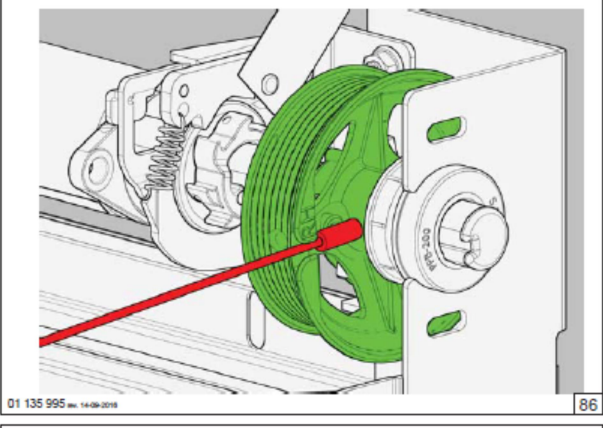
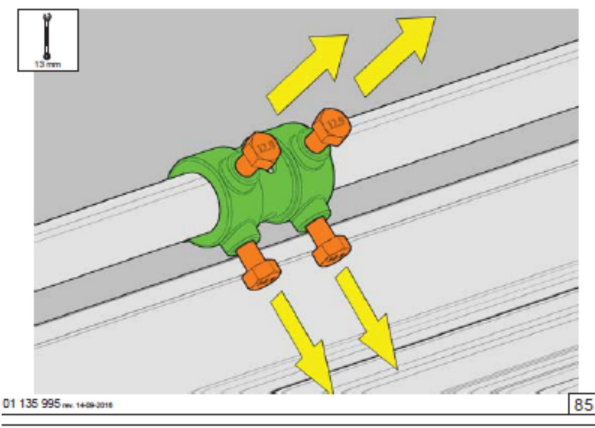
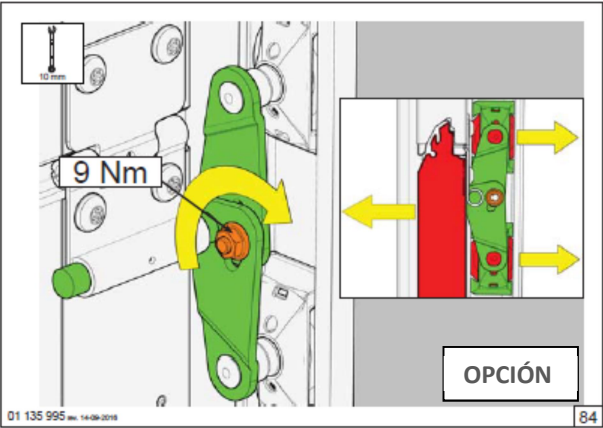
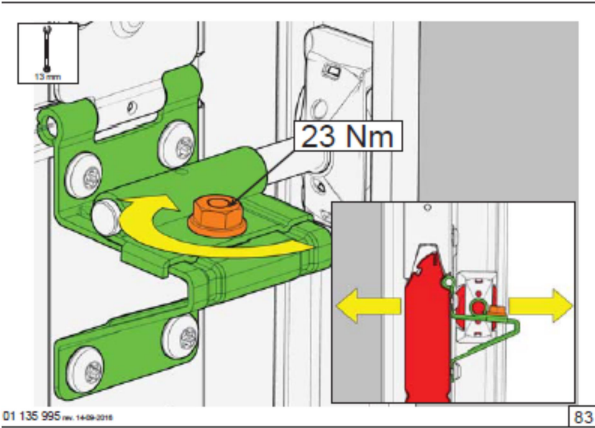

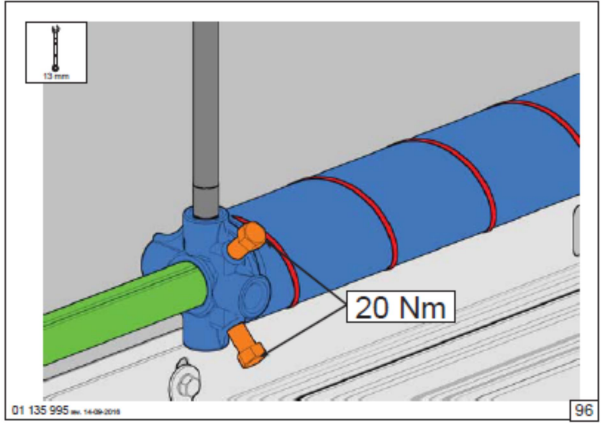
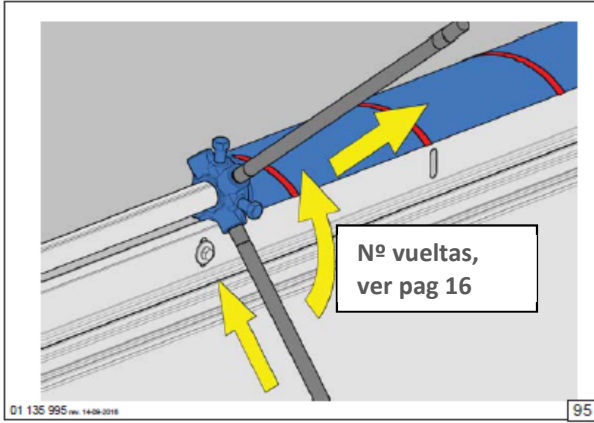
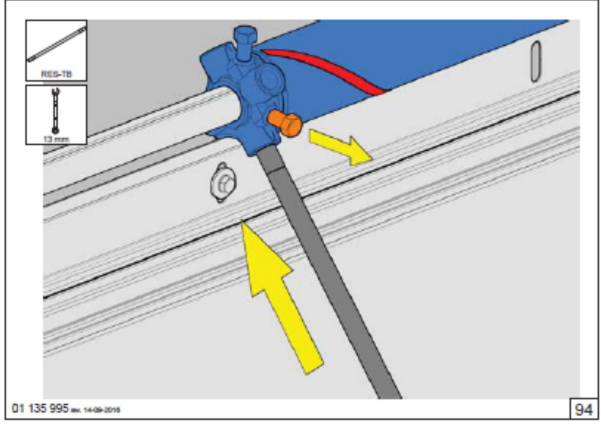
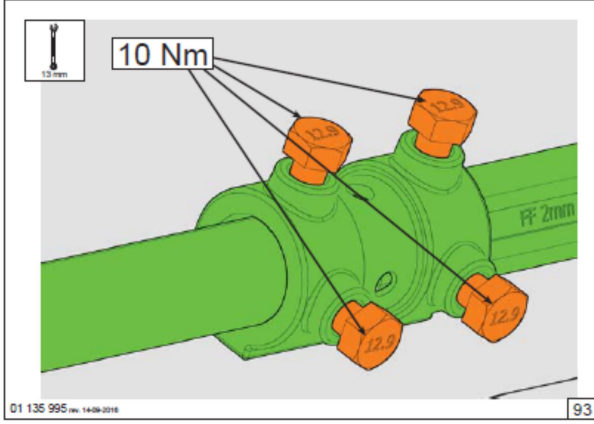
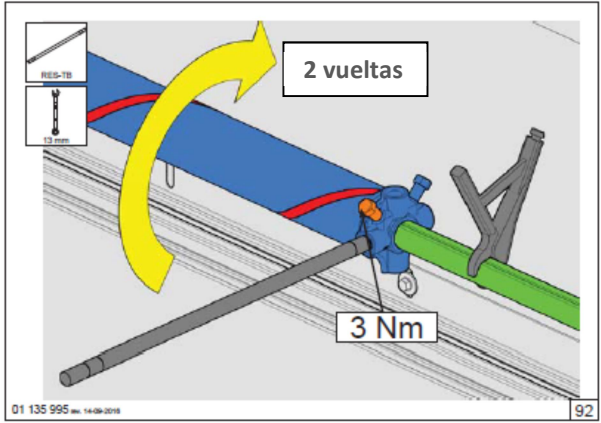
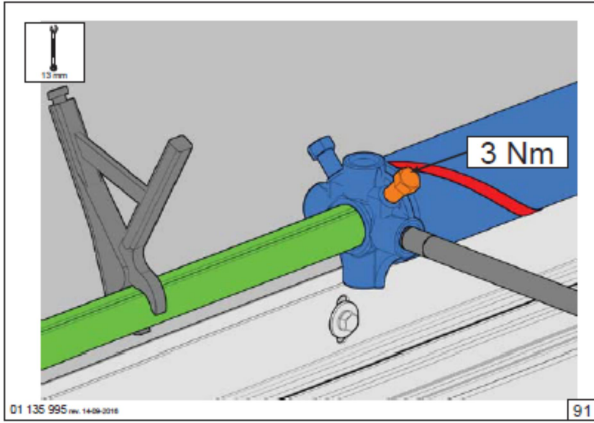
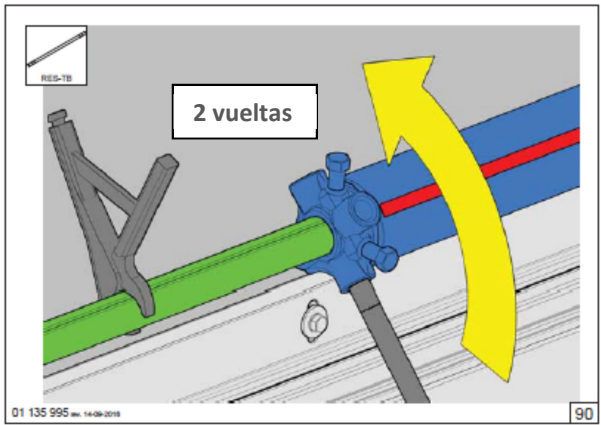
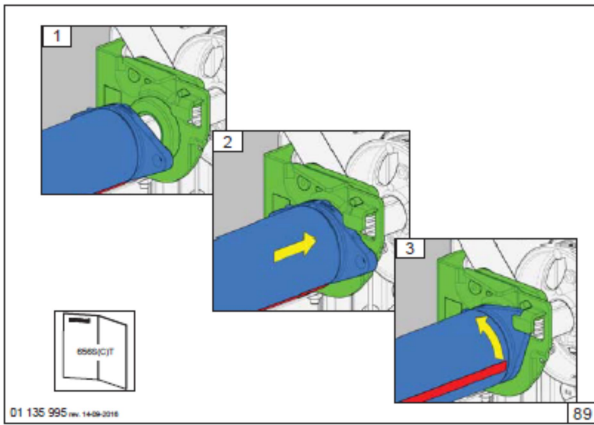

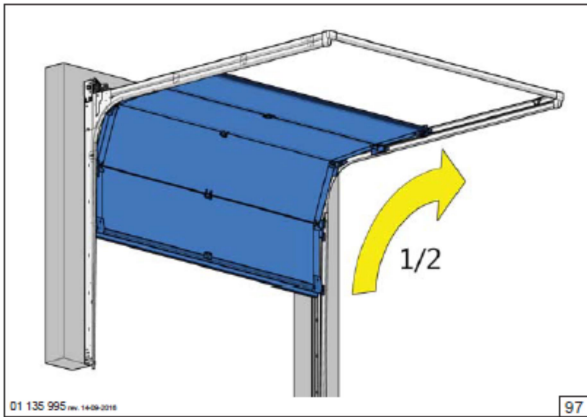

01 135 995 Rev. 14-09-2018

97

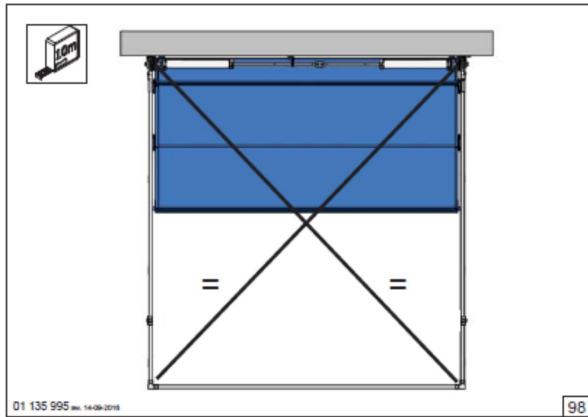

01 135 995 Rev. 14-09-2018

98

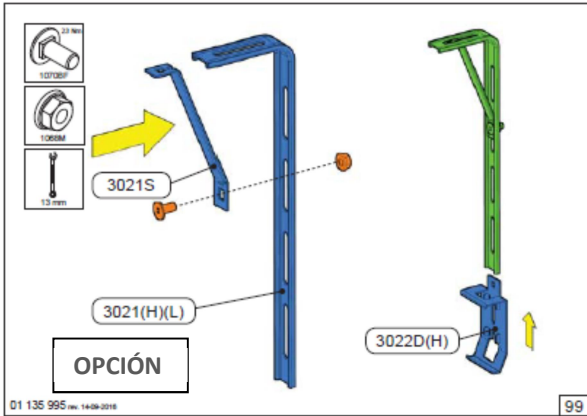

01 135 995 Rev. 14-09-2018

99

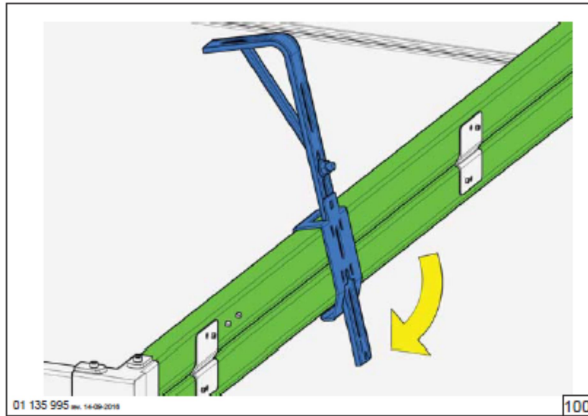

01 135 995 Rev. 14-09-2018

100

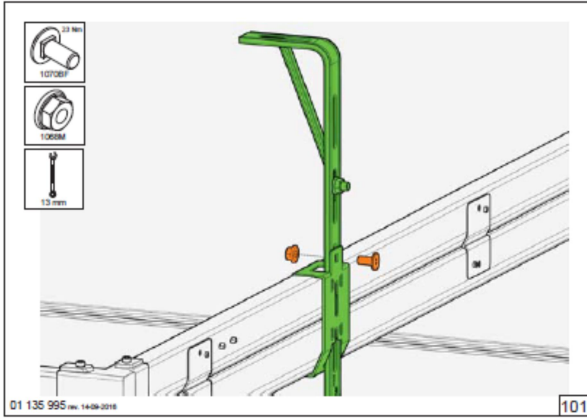

01 135 995 Rev. 14-09-2018

101

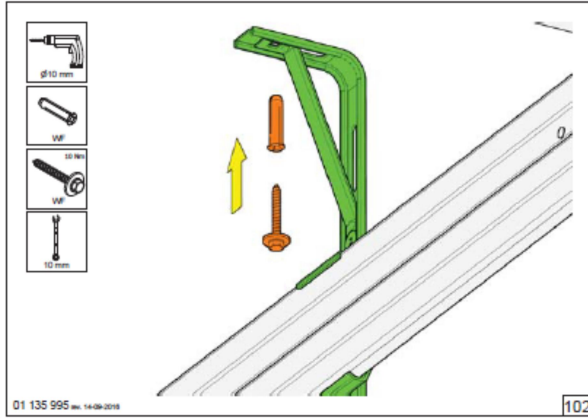

01 135 995 Rev. 14-09-2018

102

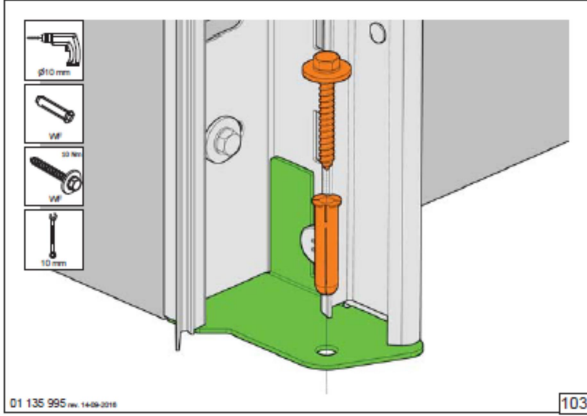

01 135 995 Rev. 14-09-2018

103

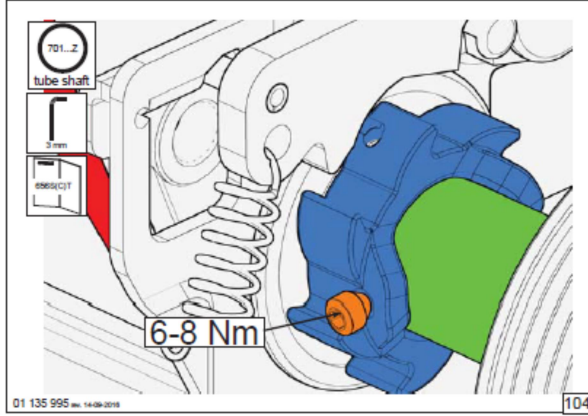

01 135 995 Rev. 14-09-2018

104

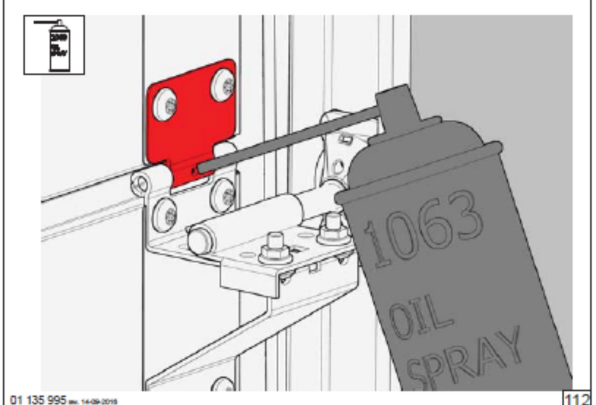
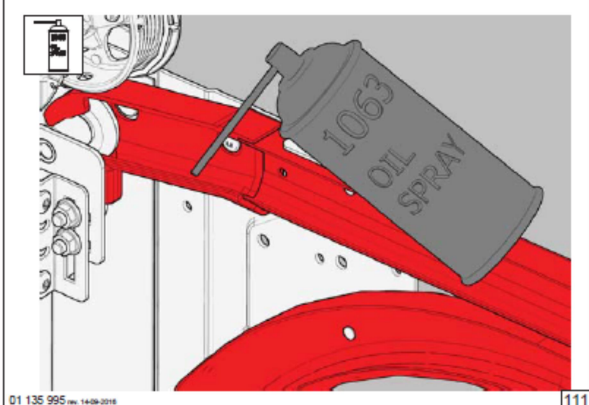
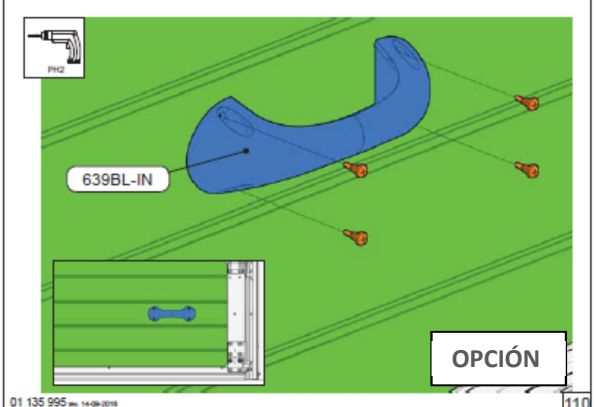
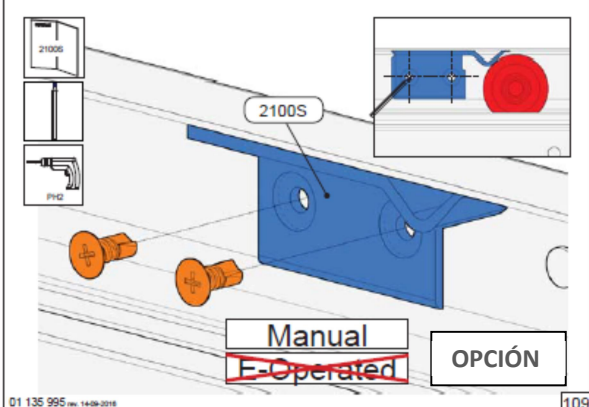
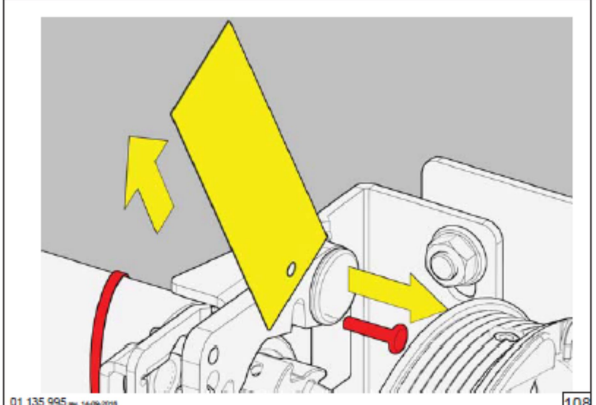
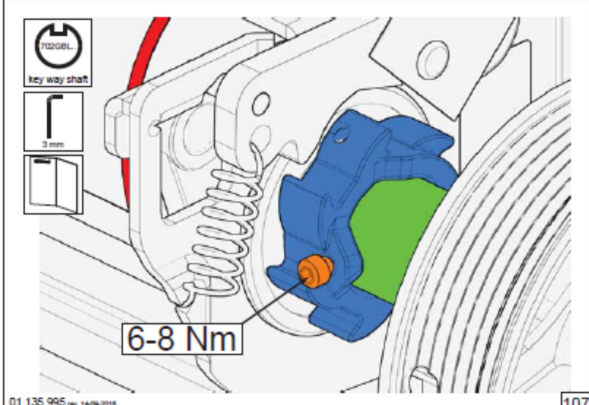
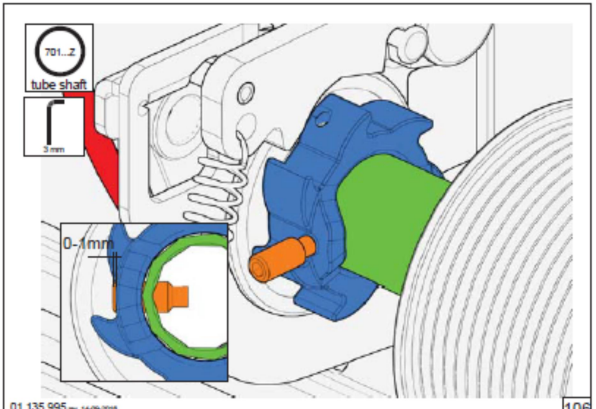
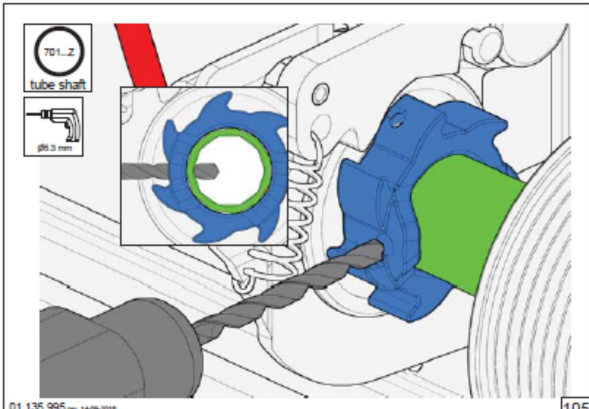

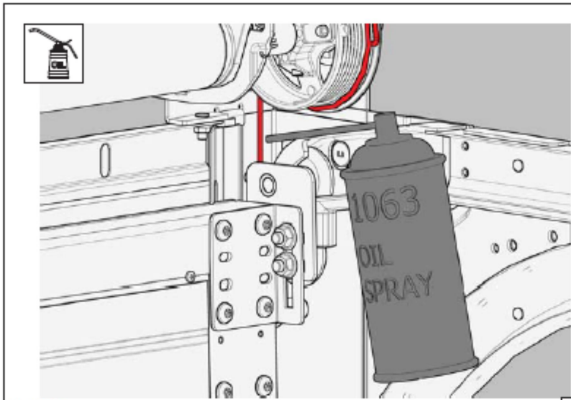

01 135 995 Rev. 14-09-2018 113

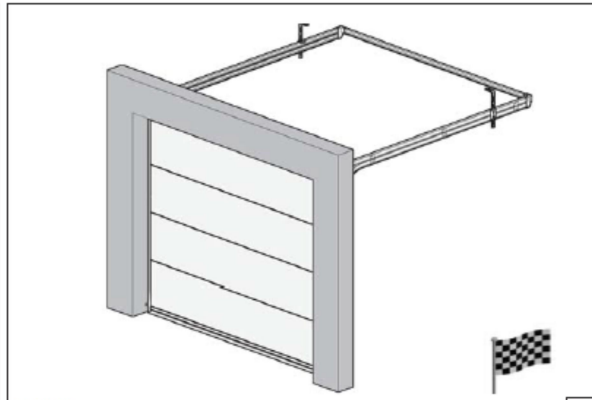

01 135 995 Rev. 14-09-2018 114

Taula de tensió de molles			
	Tambor		
Alto luz	FF05NL8	FFNL10	FF05NL12
2000	7,1	9,7	7,1
2125	7,5	10,3	7,5
2250	8	10,9	8
2375	8,1	11	8,1
2500	8,6	11,6	8,6
2750	x	x	9,4
3000	x	x	10

01 135 995 Rev. 14-09-2018 115

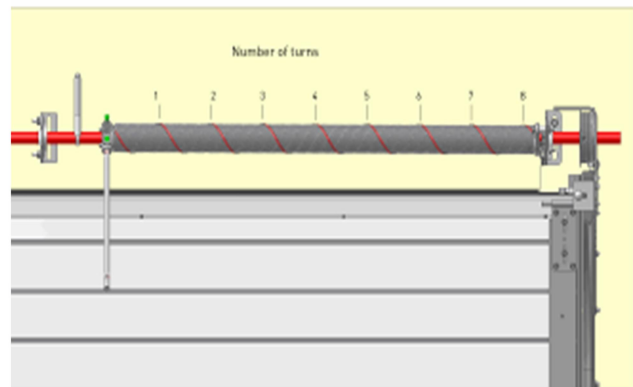

### Material de fijación al edificio

Los accesorios para fijar la puerta de garaje al edificio y/o techo, no están incluidos.

Es responsabilidad del instalador asegurarse de que la estructura del edificio es segura y lo suficientemente fuerte para la puerta y sus fijaciones. La empresa instaladora es responsable de usar los materiales de fijación correctos en la superficie correcta. En la sección de imágenes no se incluirá por tanto ninguna especificación.

### Mantenimiento

De acuerdo con las normas de la UE, hay que realizar regularmente el mantenimiento y la revisión del sistema de la puerta residencial. Es necesario registrar por escrito el mantenimiento. Deberá ser realizado exclusivamente por personal cualificado, o una empresa de puertas residenciales acreditada.

- 1-Lubrique la pieza móvil de las guías (pulverización de PTFE)
- 2-Lubrique los cojinetes y ejes del rodillo
- 3-Lubrique los ejes de las bisagras intermedias y laterales
- 4-Lubrique las juntas de goma (grasa especial para goma o vaselina)

### Después de 3 meses (por un instalador)

Comprobar el sistema de equilibrado, si fuera necesario ajustar la tensión del muelle. Inspección visual del sistema.

### Cada 6 meses o 750 ciclos (por el usuario)

Comprobar la junta lateral, superior e inferior, lubricar las piezas móviles con pulverización PTFE, limpieza de los paneles ( utilice jabón para limpieza de automóviles con agua, no utilice detergentes abrasivos, elimine la suciedad de la puerta y sus alrededores. Si denota algún daño o desperfecto, consulte con un especialista para la reparación. Si la puerta está prevista de fotocélula, debe revisarse la operación ( al cerrar, cortar la fotocélula con la mano, la puerta debe detenerse o invertir la maniobra)

### Cada 12 meses o 1500 ciclos ( por un instalador autorizado)

Comprobar los cables y las conexiones finales y abrazaderas en cuanto a desgaste, comprobar la tensión del muelle en funcionamiento manual, comprobar los rodillos, bisagras, fijaciones de muelles, juntas laterales, juntas inferior y superior y paneles. Comprobar motor de la puerta en caso de ser automatizada. (ver manual mantenimiento operador).

Utilice únicamente piezas o repuestos originales, cambiadas únicamente por un instalador autorizado. En caso de rotura de un muelle, sustituya los 2 muelles. En caso de rotura de un cable, sustituya los 2 cables.

KEY AUTOMATION CATALUNYA

C/Càntir 20 Nau 11

08292 Esparreguera (BCN)

[www.keyautomationcatalunya.com](http://www.keyautomationcatalunya.com)